

Code ST02	Project A39-A	Release D	TECHNICAL DATASHEET
---------------------	-------------------------	---------------------	----------------------------

DIGITAL READOUT VISION 900

GENERAL FEATURES

- Compact-design, modern and functional digital readout, equipped with the new **Absolute Warning System (AWS)**.
- AWS constantly guarantees the correctness of the displayed positions and informs the operator of any malfunctioning. The user can continue machining or, based on the error message displayed, intervene to restore the proper functioning of the system.
- Absolute (SSI protocol) or incremental encoder input signals.
- 5.7" touch-screen color, LED-backlit LCD TFT panel which allows the displaying of up to 4 axes.
- USB, Touch Probe, CAN bus and serial RS-232 interfaces.
- Resolutions up to 0.1 μm .
- Online HELP. Graphic visualization of function execution.
- Diagnostic of readout and encoders. Reading of coded reference indexes (in combination with NCS scale).
- Absolute signals RS-422: Clock, Clock, Data, Data.
- Universal software for any kind of machine tool; updates through serial port. 1000 memory blocks.
- Option: flush-mounted version (on a panel).



MECHANICAL AND ELECTRICAL CHARACTERISTICS

Available resolutions	1000 - 500 - 200 - 100 - 50 - 20 - 10 - 5 - 2 - 1 - 0.5 - 0.2 - 0.1 μm * 1° - 0.5° - 0.2° - 0.1° - 0.05° - 0.02° - 0.01° - 0.005° - 0.002° - 0.001°
Display	5.7" color, LED-backlit LCD TFT
Incremental encoder input signals	2 square waves with phase displacement of 90° \pm 5° + synchronized index 5 Vdc
Maximum input frequency	300 kHz
Absolute (SSI) encoder input signals	RS-422 – Clock, <u>Clock</u> , Data, <u>Data</u>
Power supply	230 Vac \pm 10% - 50/60 Hz / 110 Vac \pm 10% - 60 Hz / 24 Vac \pm 10% - 50/60 Hz
Current consumption	60 mA _{MAX} (230 Vac) / 120 mA _{MAX} (110 Vac) / 500 mA _{MAX} (24 Vac)
Connectors	D-SUB 9p F (axes), D-SUB 9p M (RS-232, CAN bus, Touch Probe), USB-B (USB)
Memory	permanent for configuration and special functions
Protection class (EN 60529)	IP 40 IP 54 with plastic cover provided
Operating temperature	0 °C \pm 50 °C
Storage temperature	-20 °C \pm 70 °C
Weight	1120 g
Version	standard or flush-mounted
Options	CAN interface

* Resolution 0.1 μm is available only for measuring lengths up to 1600 mm.

ABSOLUTE (SSI) ENCODER PARAMETERS

Clock frequency	125 / 250 / 500 kHz
Number of position bits	8-32 bit
Output code	Binary, Gray
Optional bits	Parity bit, Error bit

WARNING

- The instrument must be installed by specialized personnel in observance of the instructions provided by the Manufacturer.
- We recommend the use of a mains power supply provided with an input filter and fuses; the power distribution network to which the instrument is connected must be equipped with a sectioning device in compliance with the regulations in force, positioned closed to the instrument.
- In order to prevent fire or explosions, do not use the instrument in the presence of flammable gas, solvents, explosives, etc.
- Before installing the instrument, make sure the machine to which it will be applied complies with 2006/42/EC Directive.
- All of the equipments connected to the instrument must have insulation characteristics in compliance with the regulations in force.
- The instrument cannot be opened by non-specialized personnel. In addition, mains power must not be connected.
- The front panel can be cleaned only after disconnecting power supply, using a moist cloth. Do not use solvents.
- The measuring systems must be installed following the instructions provided by the Manufacturer.

Code ST02	Project A39-A	Release D	TECHNICAL DATASHEET
---------------------	-------------------------	---------------------	----------------------------

FUNCTIONS

INVERSION OF COUNTING DIRECTION SCALE ZERO REFERENCE (REF) SELF-TESTING ABSOLUTE / INCREMENTAL COUNTING POSITION RESET / PRESET MM / INCH CONVERSION MIDPOINT CALCULATION F 0 MEMORY CLEARING F 9 SETTING PRINTING LINE SPACINGS F 26 CONSTANT PITCH F 28 AXIS COUPLING F 30 LINEAR CORRECTION F 31 NON-LINEAR CORRECTION F 32 SCALE FACTOR F 34 RADIUS / DIAMETER CONVERSION F 36 VARIABLE RESOLUTION F 37 SEXAGESIMAL DEGREES READING F 38 ANGULAR READING F 44 TAPER CALCULATION F 46 AUTOMATIC TAPER CALCULATION F 48 THREADS CALCULATION F 50 MATERIAL WEIGHT CALCULATION F 52 PERIPHERAL SPEED CALCULATION F 54 ANGULAR SPEED CALCULATION F 55 ENABLING THE AUTOMATIC TRANSMISSION OF POSITIONS	F 64 ROUND FLANGE F 66 SPECIAL ROUND FLANGE F 68 INCLINED CONSTANT PITCH F 69 ZERO APPROACHING ALERT F 70 PROGRAMMING THE MEMORY BLOCKS F 72 CIRCUMFERENCE CENTER F 74 MIRROR IMAGE F 78 SCALE FACTOR DISPLAYING F 80 AXES SPEED DISPLAYING F 82 BUZZER ON / OFF F 89 DEVICE DIAGNOSTIC F1 - F8 SPECIAL FUNCTIONS RECALL HELP ONLINE HELP INFO INSTRUMENT CONFIGURATION INFO TOOLS 100 TOOL OFFSETS ORG 100 ORIGINS OF THE AXES CALC CALCULATOR CRONO STOPWATCH F 98718 SETTING THE TYPE OF SPINDLE ROTATION SPEED F 98757 TOUCH PROBE F 98760 AXES DISPLAY CONFIGURATION F 98762 LANGUAGE SELECTION F 98771 SSI PARAMETERS CONFIGURATION
---	--

DIMENSIONS

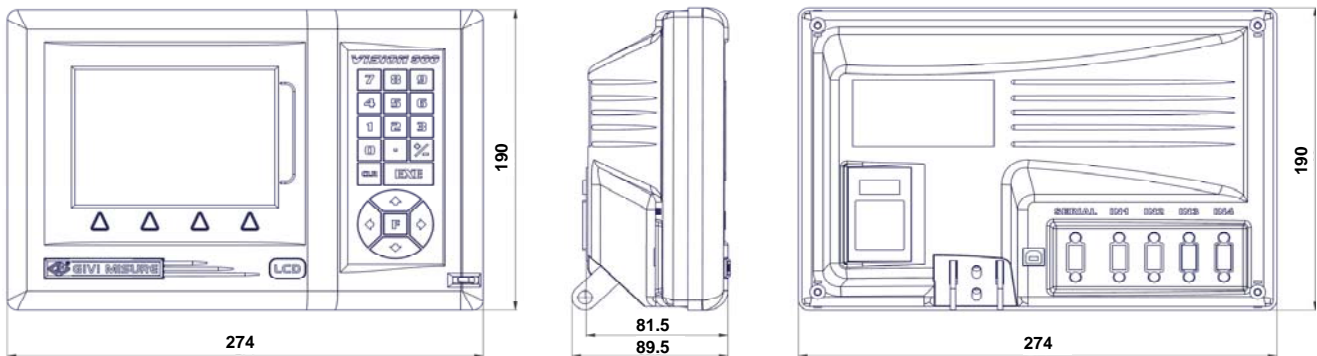

For the panel mountable version, drilling template 271x187 mm.

ORDERING CODE

MODEL	DISPLAYED AXES	INPUT AXES	MACHINE	POWER SUPPLY	VERSION	RESOLUTION	OPTIONS
VI9	3	3	TO	230V	0	1	2
	2 = 2 axes 3 = 3 axes 4 = 4 axes	2 = 2 axes 3 = 3 axes 4 = 4 axes	IN = GENERIC TO = LATHE FR = MILLING FV = VERTICAL MILLING FT = TRANSV. MILLING AL = BORING	230V = 230 Vac 110V = 110 Vac 24V = 24 Vac	0 = standard 1 = flush-mounted	1K = 1000 μm 10 = 100 μm 100 = 10 μm 1 = 1 μm 0.1 = 0.1 μm 1G = 1° 0.5G = 0.5°	2 = SSI inputs 3 = SSI inputs + CAN interface (*) (*) Only for use with RB900

Example  **DIGITAL READOUT VI933 TO 230V 0 1 2**